

GaugeCalHP Operation Manual



Contents

Overview	1
Introduction	1
Features	2
Setup	3
Assembly	3
Mounting	4
Safety Instructions	5
General Cautions	5
Operating Instructions	6
Generating Pressure	6
Operation	9
Connection Diagram	12
GaugeCalHP to Crystal Reference Indicator	12
Specifications	13
Performance	13
Materials	13
Dimensions	13
Accessories	13
Shipping Information	13
Support	14
Troubleshooting	14
Maintenance	14
Ordering Information, Spare Parts, and Fitting Kits	15
Contact Us	16
Factory Service	16
Warranty	16

Overview

INTRODUCTION

Thank you for purchasing a GaugeCalHP™ Pressure Comparator from Crystal Engineering. The GaugeCalHP is a self-contained, precision hydraulic pressure comparator intended for the calibration of pressure gauges rated up to 15 000 psi / 1000 bar / 100 MPa. You may fill the GaugeCalHP with your choice of water or oil.

Using this comparator for calibration is much faster than deadweight testers and most automated pressure controllers. The GaugeCalHP is so quick and easy to use, it is ideal for calibrating those low cost gauges that are often overlooked for ISO9000 compliance.

In fact, you can calibrate most gauges, transmitters, pressure safety valves, sensors, and switches in less than ten minutes (5 to 10 test points, increasing and decreasing pressure) using the methods described in this manual.

Spend a few minutes to read this manual and learn how you can get the most benefit from your GaugeCalHP.

Note: We recommend using one of the following indicators with the GaugeCalHP.



nVision Reference Recorder



30 Series Pressure Calibrator



XP2i Digital Pressure Gauge

FEATURES

Each comparator includes a fine adjust for precise pressure adjustments. The reference indicator threads directly to the CPF Male fitting. The device under test connects to the supplied 1/4" Female NPT fitting. For more sizes see the [Connection Diagram on page 12](#) and the [CPF Datasheet](#).

Parts Included with the GaugeCalHP

Part Number	Description
—	CPF Male Fittings (2)—non-removable
MPF15K-1/4FPT	1/4" Female NPT Fitting (1)
5102	Fine Adjust (installed)

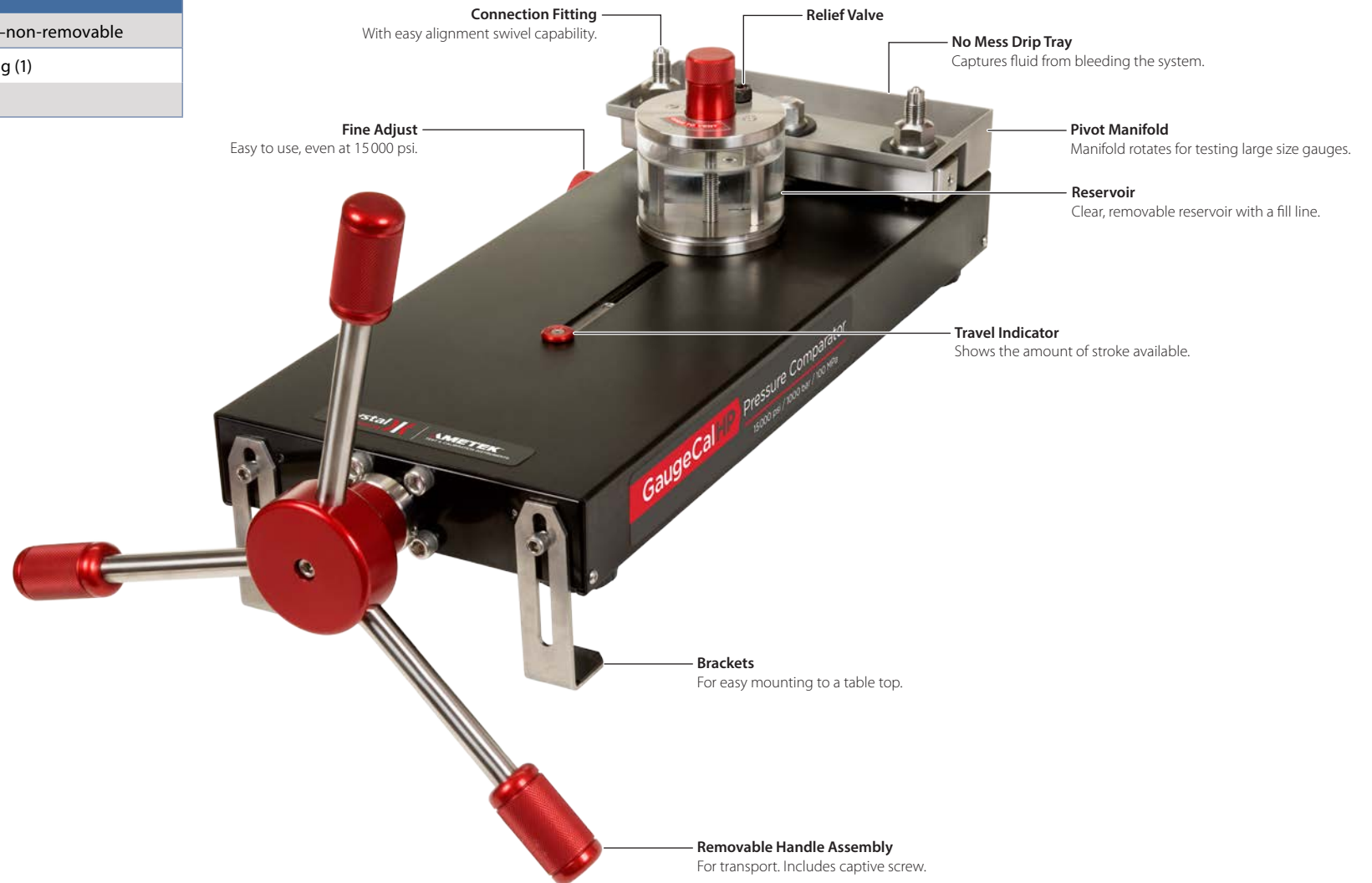

Setup

ASSEMBLY

► Install the Handle Assembly

- Install the handle assembly by tightening the captive screw using the included wrench.

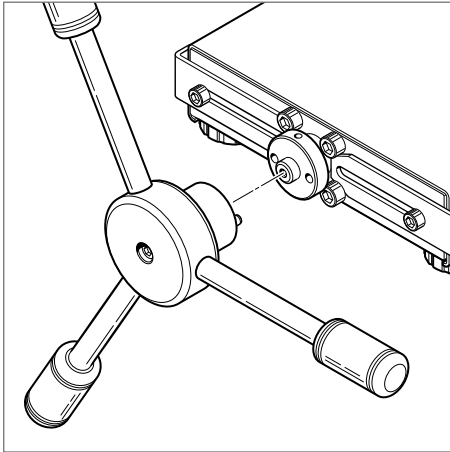

► Install the No Mess Drip Tray

- Press the no mess drip tray onto the pivot manifold.

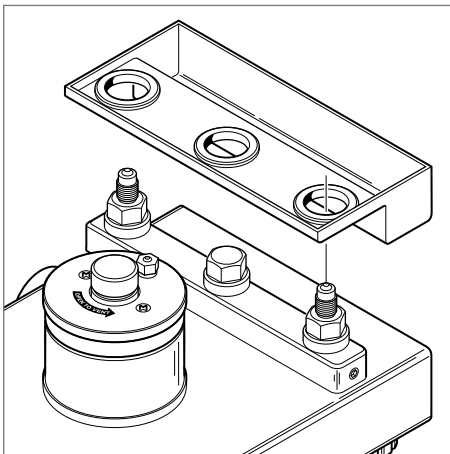

MOUNTING

The GaugeCalHP includes rubber feet that stabilize the unit up to 5000 psi. At pressures above 5000 psi, the force required to rotate the handle may cause the base of the comparator to lift. One of two methods may be used to mount the GaugeCalHP to a bench or table.

► Using the Mounting Brackets

- 1 Loosen the mounting bracket screws.
- 2 Rotate the brackets, then slide them over the front of your table (max thickness of 1.75”).
- 3 Tighten the mounting bracket screws.

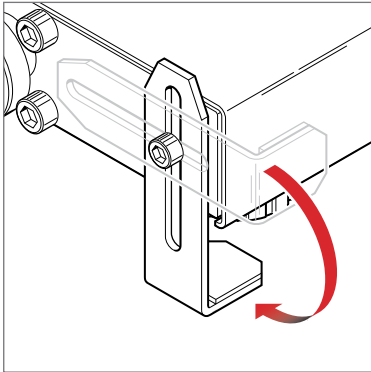

Rotate the mounting brackets...

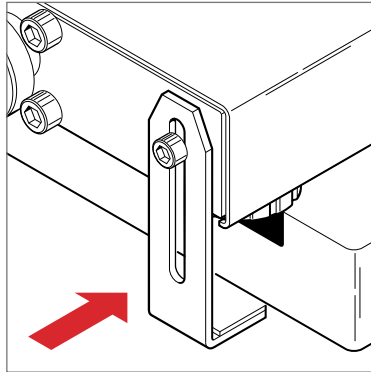

then slide them over the front of your table.

Note: To ensure the comparator is mounted securely, grip and compress the brackets to the underside of the table while tightening the mounting screws.

► Install Onto a Table

- Order the optional Table Mount Kit (P/N 5191) to bolt to a table.

Safety Instructions

Follow these instructions for safe and reliable operation of your GaugeCalHP Pressure Comparator.

GENERAL CAUTIONS

- Avoid knocking, bumping or dropping the pressure system. This can cause permanent damage to the system and loss of accuracy.
- The pressure system must not be used for any purposes other than those described in this manual and for any application other than precision pressure calibration jobs.
- The pressure system should only be used by TRAINED PERSONNEL.
- None of our calibration systems are cleaned or prepared for OXYGEN SERVICE. **DO NOT USE** our systems for this purpose.
- Do not disconnect any parts from the system when pressurized.
- Do not connect any external pressure source to this system. This system is designed to test pressure measuring devices connected to the manifold only. Pressure from an external source can result in explosion of the fluid reservoir and possible personal injuries.
- The pressure inside the pump can be extremely high. Ensure that all pressure connections have been established correctly.

Operating Instructions

GENERATING PRESSURE

► Prepare the Fine Adjust

- Turn the fine adjust counter-clockwise about 10 rotations to provide room to increase or decrease pressure as needed.

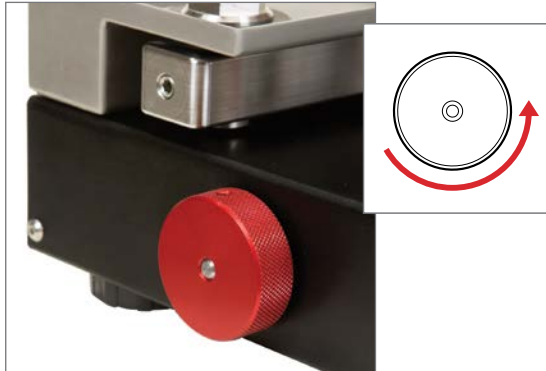

► Fill the Reservoir

The test fluid can be either water or lightweight oil.

Note: If using oil, we recommend AMETEK MGAAA oil.

- 1 Turn the handle fully counter-clockwise until it stops.
- 2 Turn the reservoir knob fully counter-clockwise and remove it from the reservoir.

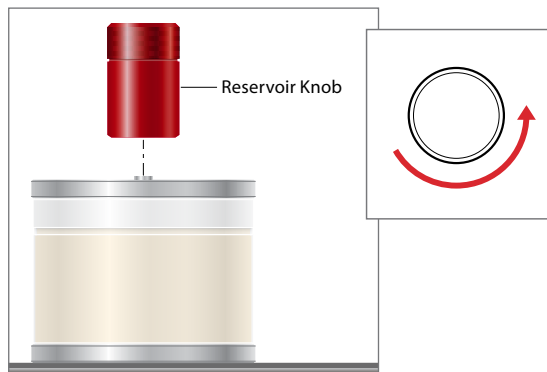

3 Fill the reservoir to the fill line.

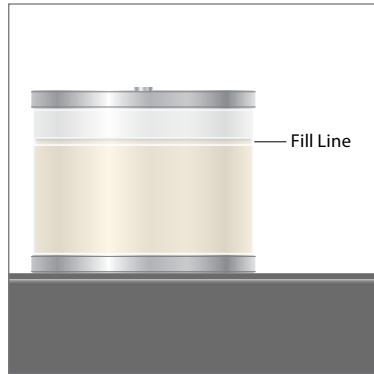

► Bleed Air from the System

- Tighten the reservoir knob clockwise until fluid comes out of the fittings. The drip tray will collect the spilled fluid.

► Install the Device Under Test

Your GaugeCalHP comes with two CPF male fittings (non-removable) and an adapter to 1/4" Female NPT that is rated to 15 000 psi (P/N MPF15K-1/4FPT).

1 Connect the adapter to your device under test.

You will need to use thread tape or sealant to create a leak free seal.

2 Loosely tighten (3 turns only) the other end of the adapter to the connection manifold.

Note: For additional sizes and pressure ratings, see the [Connection Diagram on page 12](#).

For applications up to 10 000 psi, create finger-tight, leak-free seals by using CPF fittings. [Visit the website for more information on CPF.](#)

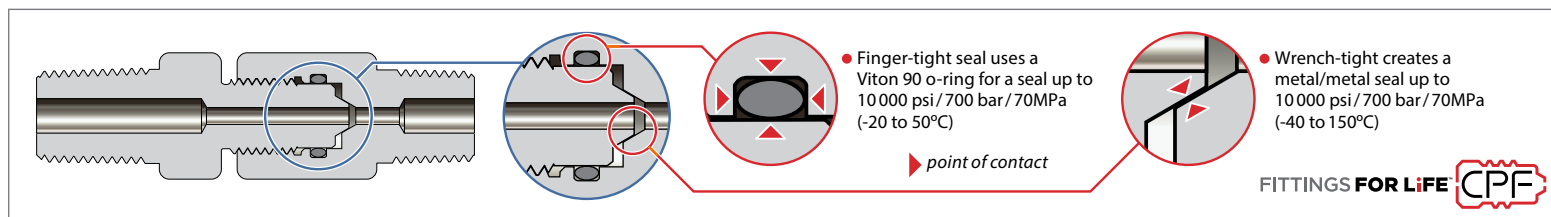

Note: If you are using CPF quick test fittings, do not use thread tape.

! CAUTION: Never use a wrench to tighten quick test fittings.

► Install the Reference Indicator

1 Loosely tighten (3 turns only) the reference to the connection manifold.

Note: If the reference will not fit because you have a large device under test, turn the pivoting manifold to create extra space.



Shown with a Quick Test Fitting (not included).

2 Bleed the system of remaining air by turning the reservoir knob clockwise until fluid drips out of the CPF weep hole on the base of the reference and on the connection fitting.

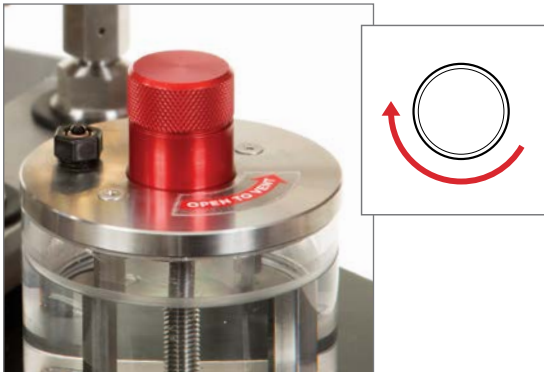

Turn the reservoir knob...



until fluid drips from the CPF weep hole.

- 3 Tighten the reference and the device under test. The connection only needs to be finger tight for a seal to 15 000 psi.
- 4 If necessary, continue to turn the devices clockwise until they are in the desired position.



Note: If necessary, fill the fluid in the reservoir back up to the fill line.

OPERATION

► Perform a Calibration

- 1 Vent the system by turning the reservoir knob counter-clockwise until a gap is visible between the reservoir knob and the lid.

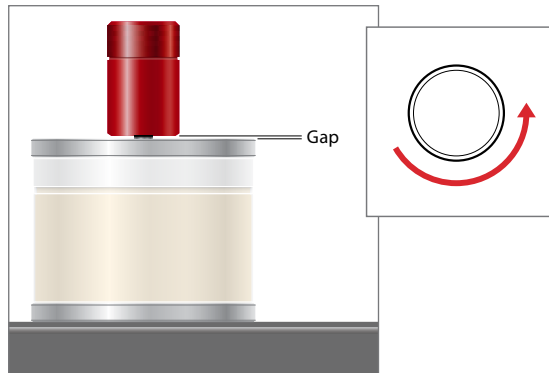

- 2 Turn on the reference indicator, and then select the pressure units required for the gauge to be tested.
For detailed operating instructions, refer to the documentation you received with your reference.

3 Press the **(zero)** button on your reference.

We recommend that you exercise the device under test by applying the full scale pressure one or more times.

4 To apply pressure... Turn the handle in a clockwise direction.

5 To decrease pressure... Turn the handle in a counter-clockwise direction.

After decreasing the pressure to zero, recheck the fluid level in the reservoir and rezero the reference, if necessary. You will notice that the application of pressure is non-linear, therefore pressure increases at a more rapid rate at higher pressures.

6 Turn the handle clockwise until the approximate pressure is obtained.

7 Allow time for the adiabatic effect to stabilize.

8 Use the fine adjust knob to obtain the exact pressure.

9 Compare the pressure on the device under test to the pressure displayed on the reference, and record the reading.



Checking the accuracy of an analog pressure gauge against the display of the reference.

► Perform a Quick Test Calibration

An alternative method eliminates the time required to wait for thermal pressure stability. This method works with the Crystal XP2i and nVision, but not with the 30 Series.

- 1 Set the reference to detect peaks and clear any stored peak value.
- 2 Slowly increase pressure to the first major graduation on the device under test (or to the first calibration point). Increase pressure *slowly*, so that you don't overshoot the mark (or point).

The maximum pressure displayed on the reference will be the pressure that was applied—even if actual pressure drops again immediately.

- 3 Record the peak reading and continue to the next test point or mark.

If you are also checking the gauge for hysteresis, the procedure is the same, except that you start at full scale and set the reference for the peak low. Eliminating the time required to wait for thermal equilibrium, significantly shortens the amount of time it takes to calibrate a gauge.

Note: To automatically collect the readings directly from the reference, use [FastCalXP calibration software](#).

► To vent the system

- Turn the handle counter-clockwise until it stops.

Vacuum Use

► To Generate Vacuum

- 1 Loosen the reference indicator about 3 turns counter-clockwise.
- 2 Turn the handle clockwise and verify that fluid is dripping out of the CPF weep hole into the drip tray. Continue to turn the handle until it stops.
- 3 Tighten the reference.
- 4 Rotate the handle counter-clockwise to generate a vacuum.

You can generate up to -12.5 psi.

Note: Be aware that the system will vent during the last inch of travel.

Connection Diagram

GAUGEALHP TO CRYSTAL REFERENCE INDICATOR

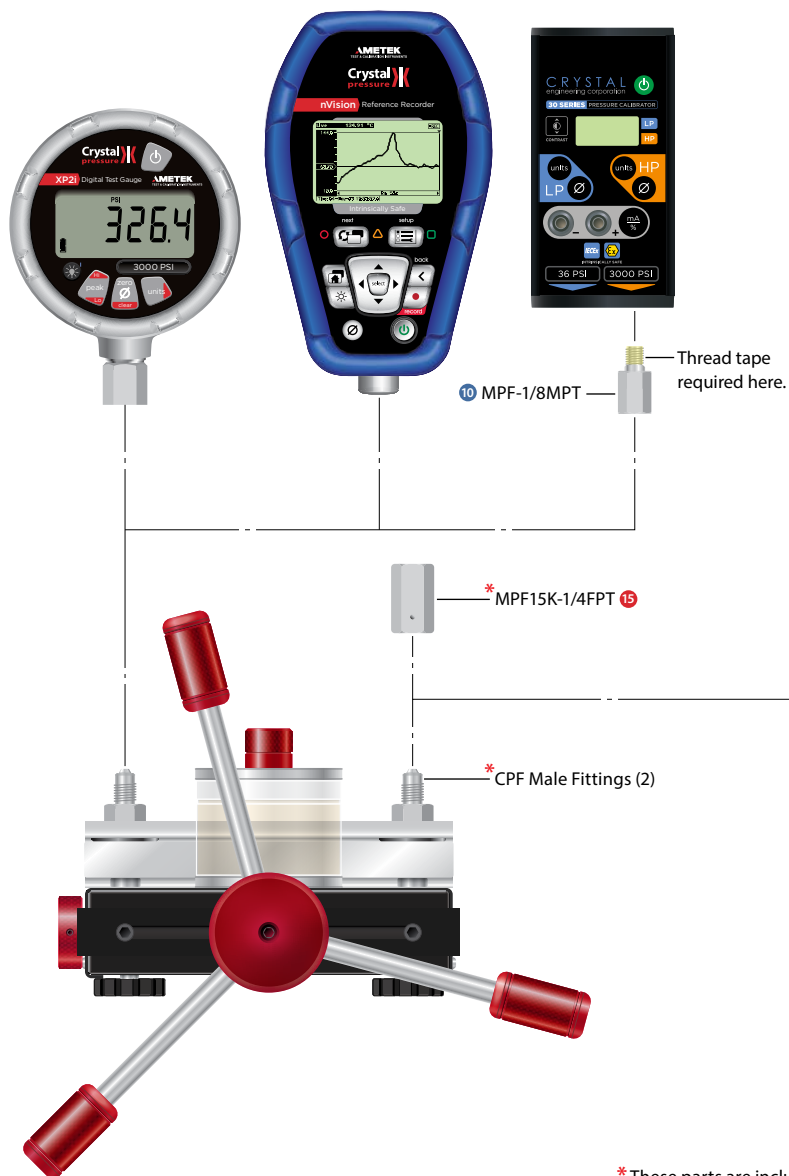

► CPF Fittings

NPT MALE

MPF-1/8QTM	1/8" Quick Test NPT Male	10
MPF-1/8MPT	1/8" NPT Male	10
MPF-1/4QTM	1/4" Quick Test NPT Male	10
MPF-1/4MPT	1/4" NPT Male	10

Additional NPT sizes available in non-CPF MP adapters

NPT FEMALE

MPF-1/8QTF	1/8" Quick Test NPT Female	10
MPF-1/4QTF	1/4" Quick Test NPT Female	10
MPF-1/4FPT	1/4" NPT Female	10
MPF-1/2QTF	1/2" Quick Test NPT Female	5

Additional NPT sizes available in non-CPF MP adapters

BSP

MPF-1/8BSPF	G 1/8" Female	10
MPF-1/4BSPF	G 1/4" Female	10
MPF-3/8BSPF	G 3/8" Female	10
MPF-1/2BSPF	G 1/2" Female	10

TRANSMITTER

MPF-5/16TRM	for Foxboro, Rosemount, & Yokogawa	5
MPF-1/4TRM	for Honeywell	5

TUBE

MPF-1/4TBM	1/4" Tube Male	5
MPF-3/8TBM	3/8" Tube Male	5
MPF-1/2TBM	1/2" Tube Male	5

CPF

MPF-MPF	Female to Female	10
MPF-MPFTU	T-Union (Female)	10
MPF-MPFBULK	Bulkhead (Female to Female)	10
MPF-CAP	Cap	10

ADDITIONAL

MPF-M20QTF	M20 x 1.5 Quick Test Female	5
MPF-M20X1.5F	M20 x 1.5 Female	10
MPF-QCN	Quick-Connect Nut	5
MPF-AN4M	AN4 Male	5

► Non-CPF MP Fittings

Medium Pressure FEMALE to NPT FEMALE

4501	1/8 NPT	15
4715	1/4 NPT	15
4502	3/8 NPT	15
4503	1/2 NPT	15

Medium Pressure FEMALE to NPT MALE

4714	1/4 NPT	15
4494	3/8 NPT	15
4495	1/2 NPT	15
4496	3/4 NPT	10

Medium Pressure MALE to NPT FEMALE

4497	1/8 NPT	15
4498	1/4 NPT	15
4499	3/8 NPT	15
4500	1/2 NPT	15

Medium Pressure MALE to NPT MALE

4698	1/4 NPT	15
4492	3/8 NPT	15
4493	1/2 NPT	15

5 300 bar/5000 psi

10 700 bar/10000 psi

15 1000 bar/15000 psi

(Non-CPF MP adapters require wrench tightening.)

* These parts are included with the pump. All other parts are supplied as part of a pump system, or may be ordered separately. All BSP connections require bonded seals.

Specifications

PERFORMANCE

Hydraulic Pressure

Maximum 15 000 psi / 1000 bar

Vacuum -12.5 psi / -0.86 bar / -86.2 kPa

Pneumatic Pressure

Maximum 400 inH₂O / 995 mbar

Sensitivity (fine adjust) 0.01 inH₂O / 0.025 mbar

Burst Pressure

Pressure >25 000 psi / 1700 bar

MATERIALS

Wetted Materials Stainless Steel plus Seals and Acrylic Reservoir

Enclosure Anodized Aluminum

Seals Buna N (Nitrile), Viton, and Urethane

Test Media Water, Oil, or Air

DIMENSIONS

Width 8.3 in / 210 mm

Length 20.50 in / 520 mm

Height (base) 5.5 in / 140 mm

Height (with handles) 11 in / 280 mm

Weight 20 lbs / 9 kg

Piston Stroke Volume 0.8 in³ / 13.1 cm³

Reservoir Volume 10.8 in³ / 176.9 cm³

ACCESSORIES

Included

Adapter 1/4" Female NPT (P/N MPF15K-1/4FPT)

SHIPPING INFORMATION

Shipping Weight 22 lbs / 9.9 kg

Dimensions 24 in x 12 in x 12 in /
610 mm x 305 mm x 305 mm

Support

TROUBLESHOOTING

Unstable Pressure

► **Problem:** Pressure cannot be generated correctly, or set pressure does not remain stable.

► **Solutions:**

- Check that all adapters and pressure fittings have been tightened sufficiently to eliminate leaks.
- Confirm test fluid does not contain air (air in the fluid can increase adiabatic effects). You may have to adjust the pressure a few times before the pressure is stable enough for calibration. Replace test fluid if necessary.
- Adiabatic and thermodynamic effects may be affecting the pressure reading. High pressure hydraulic systems are sensitive to temperature and movements. This effect will disappear after a period of time.

If the pressure is still not stabilizing, the system may be in need of service. Please contact your local distributor for advice.

Note: Always readjust the pressure after 5 to 10 minutes to allow time for settling of above effects.

MAINTENANCE

Users should/must carry out the following cleaning procedures when required:

Standard exterior cleaning Clean using a soft, damp cloth.

Heavily soiled cleaning The instrument may also be cleaned using isopropyl alcohol when heavily soiled.

Reservoir Can be removed for easy cleaning. Turn the GaugeCalHP onto its side and loosen the two screws holding the reservoir in place. Slide the screws through the hole and quickly remove the reservoir as fluid may leak out of the bottom.

To clean the clear acrylic reservoir tube use a soft cloth or soap and water only. **Never use chemical cleaners.**

ORDERING INFORMATION, SPARE PARTS, AND FITTING KITS

Ordering Information

P/N GAUGEALHP GaugeCalHP Pressure Comparator

Pressure Comparator, two CPF male fittings (installed), and one 1/4" FNPT adapter (P/N MPF15K-1/4FPT).

Spare Parts

P/N 5102 Fine Adjust (included)

P/N 5101 Rolling Case

Two MPF-CAP fittings to prevent leaks while in transit, two hold-down straps, and fluid bottle.

P/N FASTCALXP Gauge and Transmitter Calibration Software

FastCalXP software, USB Security Key, CD, and USB-RS232 adapter.

P/N 3327 USB Footswitch for FastCalXP

P/N 5191 Mounting Kit

P/N 5103 Rebuild Kit



Fitting Kits

P/N 4013 Quick Test NPT Kit—A set of CPF conversion fittings for connecting to 1/8", 1/4", and 1/2" male NPT; without tools or thread tape.

Finger-tight to working pressure up to 10 000 psi / 700 bar.

Includes (1) MPF-1/8QTF, (1) MPF-1/4QTF, and (1) MPF-1/2QTF CPF fitting.

P/N 4015 BSP Test Kit—CPF conversion fittings to connect to male BSP: G 1/8, G 1/4, G 3/8, and G 1/2. Working pressure up to 10 000 psi / 700 bar.

Includes (1) MPF-1/8BSPF, (1) MPF-1/4BSPF, (1) MPF-3/8BSPF, and (1) MPF-1/2BSPF CPF fitting.

Test Fluid

► Recommended Oil

P/N: MGAAA/QT ...Hydraulic Oil. Quart.

P/N: MGAAA/GL ...Hydraulic Oil. Gallon.

CONTACT US

Phone(805) 595-5477
Toll-Free(800) 444-1850
Fax(805) 595-5466
Emailcrystal@ametek.com
Webcrystalengineering.net

FACTORY SERVICE

Please complete the [Return Material Authorization \(RMA\) form](#) to generate an authorization number and provide return instructions.

WARRANTY

Crystal Engineering Corporation warrants the GaugeCalHP Comparator to be free from defects in material and workmanship under normal use and service for one (1) year from date of purchase to the original purchaser. It does not apply to batteries or when the product has been misused, altered or damaged by accident or abnormal conditions of operation.

Crystal Engineering will, at our option, repair or replace the defective device free of charge and the device will be returned, transportation prepaid. However, if we determine the failure was caused by misuse, alteration, accident or abnormal condition of operation, you will be billed for the repair.

CRYSTAL ENGINEERING CORPORATION MAKES NO WARRANTY OTHER THAN THE LIMITED WARRANTY STATED ABOVE. ALL WARRANTIES, INCLUDING IMPLIED WARRANTIES OF MERCHANTABILITY OR FITNESS FOR ANY PARTICULAR PURPOSE, ARE LIMITED TO A PERIOD OF ONE (1) YEAR FROM THE DATE OF PURCHASE. CRYSTAL ENGINEERING SHALL NOT BE LIABLE FOR ANY SPECIAL, INCIDENTAL OR CONSEQUENTIAL DAMAGES, WHETHER IN CONTRACT, TORT OR OTHERWISE.

Note: (USA only) Some states do not allow limitations of implied warranties or the exclusion of incidental or consequential damages, so the above limitations or exclusions may not apply to you. This warranty gives you specific legal rights and you may have other rights which vary from state to state.



© 2013 Crystal Engineering Corporation

708 Fiero Lane, Suite 9, San Luis Obispo, California 93401-8701

