

CRYSTAL

ACCURACY

0 to 20% of range: $\pm(0.02\%$ of Full Scale)

20% to 100% of range: $\pm(0.1\%$ of Reading)

Vacuum: $\pm(0.25\%$ of Full Scale*)

* Full Scale = -14.5 PSIG

Includes all effects of linearity, hysteresis, repeatability, temperature, and stability within the specified operating temperature range for one year.

All models indicate vacuum, but vacuum specification applies to 15 PSI, 30 PSI, 100 PSI and 300 PSI models only.

Not recommended for continuous use at high vacuum. Refer to [XP2i-DP data sheet](#) for gauges that are intended for continuous high vacuum use.

OPERATING TEMPERATURE

Temperature range: -10°C to 50°C (14°F to 122°F)

Non-condensing. No change in accuracy over operating temperature range. Gauge must be zeroed to achieve rated specification.

DISPLAY

Screen: **5 digits, 16.5 mm (0.65") high**

Display Rate: **3 readings/second (standard)**
7 readings/second (PSV mode)

LCD readable in sunlight with bright backlight.

PSV mode is intended for Pressure Safety Valve testing, and requires software to enable. (ConfigXP is a free download from [XP2i.com](#).)

POWER

3 x AA: **1500 hours, typical**

Uses 3 alkaline AA (LR6) batteries. Use of backlight and/or RS232 reduces operating time.

Optional AC power supply available.

DATA/COMMUNICATION

Digital Interface: **RS232, DB-9F**

Free Labview® drivers and programming instructions are available for download from website.

DATALOGGING

Capacity: **Approx. 6000 data points**

Storage type: **Non-volatile flash memory**

Minimum Interval: **1 second**

Maximum Interval: **18 hours**

Min. event duration: **333 mS (min/max enabled)**

Firmware Update may be purchased at time of order, or an Upgrade Package may be purchased afterward.

Software available for download from our website. Compatible with 32 & 64 bit Windows 7 and Vista, and XP (32 bit only). Produces csv files, or uses Excel template files (samples included) to automatically format and graph data.

XP2i Pressure Gauge PSI

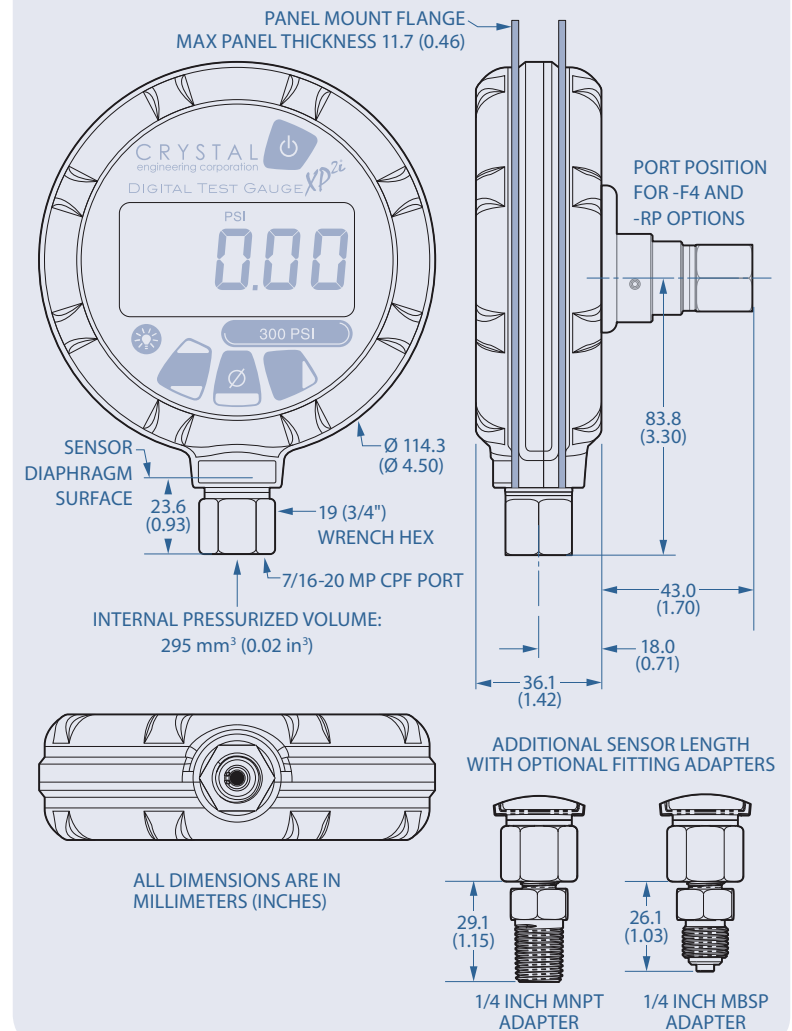

XP2i

XP2i PSI Data Sheet

4533.C | Page 1 of 3

CRYSTAL

ENCLOSURE

Weight: 562 g (19.8 oz)	<i>Weight includes batteries.</i>
Rating: IP67	<i>Submersible to 1 m for 30 minutes [IEC 60529].</i>
Housing: Diecast aluminum	<i>Nickel plating over low copper, marine grade aluminum.</i>
Keypad and labels: UV Resistant Polyester	<i>LCD protected from impact damage by 1.5 mm (0.06") thick polycarbonate lens under polyester window.</i>
	<i>Skydrol® compatible.</i>

SENSOR

Wetted materials: (WRENCH TIGHT) 316 stainless steel	<i>All welded, with a permanently filled diaphragm seal.</i>
(FINGER TIGHT) 316 stainless steel and Viton® (internal o-ring)	<i>Metal to metal cone seal; O-ring can be removed if necessary</i>
Diaphragm seal fluid: Dow Corning® 200	<i>Optional connection on back.</i>
Connection: Bottom, 7/16"-20 UNF 2B female CPF	<i>¼" male NPT adapter included unless BSP is specified.</i>
	<i>Can be cleaned and certified for oxygen service.</i>

STORAGE TEMPERATURE

Temperature range: -40°C to 75°C (-40°F to 167°F)	<i>Batteries should be removed if stored for more than one month.</i>
--	---

SPECIAL FEATURES

The following requires the use of Crystal's free ConfigXP software

- User defined unit: **Allows the user to define and display any pressure units not included, or to use the gauge to display force, level or other pressure related parameters. Reduce or increase displayed resolution.**
- PSV mode: **Intended for pressure safety valve testing. 7 readings per second. Records point at which valve opens, as well as reseal pressure.**
- Averaging: **Smooths unsteady readings.**
- Remove: **Unwanted pressure units from Units button.**
- Disable: **Peak pressure button.**
- Limit or Disable: **Zero button.**
- Password protect: **Changes to configuration or calibration factor(s).**
 - Save: **Configuration to a file.**
 - Copy: **Configuration can be copied to other gauges.**

XP2i Pressure Gauge PSI

CERTIFICATIONS



II 1G Ex ia IIC T4 Gb
KEMA 04 ATEX 1053 X

This product conforms to:
EN60079-0: 2006
EN60079-11: 2007
EN60079-26: 2007



II 1G Ex ia II T4 Gb
IECEX CSA 05.0001X

This product conforms to:
IEC 60079-0: 2004
IEC 60079-11: 2006



Class I, Division 1 Groups A, B, C, & D, Temperature Code T4
Intrinsically Safe and Non-incendive for Hazardous Locations.



XP2i complies with the Electromagnetic Compatibility and the Pressure Equipment Directives. Refer to the EC Declaration of Conformity for specific details.



The instrument was tested against **AS/NZS 3584**, C-tick EMC/EMI requirements.



XP2i is approved for use as a portable test instrument for Marine use and complies with Det Norsjke Veritas' Rules for Classification of Ships, High Speed & Light Craft and Offshore Standards.

XP2i

XP2i PSI Data Sheet

4533 . C | Page 2 of 3

RANGE & RESOLUTION TABLE

P/N	Range (PSI)	Over-Pressure	Display Resolution								
			PSI	inch H ₂ O	inch Hg	mmHg	mm H ₂ O	kPa	kg/cm ²	bar	mbar
15PSI	15	6.5 x	0.001	0.01	0.001	0.01	1	0.01	0.0001	0.0001	0.1
30PSI	30	3.0 x	0.001	0.01	0.001	0.1	1	0.01	0.0001	0.0001	0.1
100PSI	100	2.0 x	0.01	0.1	0.01	0.1	1	0.01	0.0001	0.0001	0.1
300PSI	300	2.0 x	0.01	0.1	0.01	1		0.1	0.001	0.001	1
500PSI	500	2.0 x	0.01	1	0.1	1		0.1	0.001	0.001	1
1KPSI	1000	2.0 x	0.1		0.1			0.1	0.001	0.001	
2KPSI	2000	2.0 x	0.1		0.1			1	0.01	0.01	
3KPSI	3000	1.5 x	0.1		0.1			1	0.01	0.01	
5KPSI	5000	1.5 x	0.1		1			1	0.01	0.01	
10KPSI	10000	1.5 x	1					1	0.01	0.01	

ORDERING INFORMATION

P/N	Model	Adapter: Type	Connection: Location	Panel Mount?	Data-logging?	Oxygen Service?
_____	<u>XP2i</u>	_____	_____	_____	_____	_____
Standard:	NPT: (omit)	Bottom: (omit)	No: (omit)	No: (omit)	No: (omit)	No: (omit)
Options:	G 1/4 B: -BSP	Back: -RP	Yes: -F4	Yes: -DL	Yes: -O	
		"omit" for -F4 panel mount	Includes -RP option			

SAMPLE PART NUMBERS

300PSIXP2I 300 PSI standard gauge
 500PSIXP2I-BSP-0 500 PSI gauge, with a 1/4" BSP pressure fitting and Oxygen Service options

ACCESSORIES



Protective Boot P/N 3696

Protect your XP2i even more from harsh environments with our form fitting chemical resistant thermoplastic boot (Skydrol fluid compatible).

AC Adapter Kit P/N 2984

For continuous use applications without battery replacement concern. Input voltage: 100 - 240V, 50-60 Hz. Includes all available international plugs. (Not for use in hazardous locations.)

COMPLIMENTARY PRODUCTS

Crystal Engineering offers a wide range of products that work with the XP2i:

- [Fittings that connect without tools, safely and without leaks](#)
- [Lightweight, super flexible high pressure hoses](#)
- [Fitting kits and adapters](#)
- [Pneumatic hand pumps](#)
- [Hydraulic hand pumps](#)
- [Portable pressure comparators](#)
- [Software, for the quickest way to calibrate pressure transmitters and gauges](#)

Dow Corning is a registered trademark of Dow Corning Corporation.